

TFA4TM

TOWER
FLANGE
ALIGNMENT
TOOL



CONTENTS

1. INTRODUCTION
2. TOOL SAFETY
 - 2.1 GENERAL SAFETY
 - 2.2 PERSONNEL COMPETENCY
 - 2.3 DISCLAIMER
 - 2.4 DEFINITION OF TERMS
 - 2.5 HAZARDS
3. TFA4TM MECHANICAL FLANGE ALIGNMENT TOOL
 - 3.1 TOOL CAPABILITIES
 - 3.2 RANGE OF APPLICATION
 - 3.3 TOOL FUNCTION
 - 3.4 KIT CONTENTS
 - 3.5 TOOL DIMENSIONS
 - 3.6 TOOL MAINTENANCE
4. TROUBLESHOOTING
 - 4.1 TFA4TM TROUBLESHOOTING
5. REGULATORY INFORMATION
 - 5.1 REGISTERED HEAD OFFICE
6. PARTS LISTS & SERVICE KITS

20/07/2017

1.

INTRODUCTION

The Equalizer™ TFA4™ Tower Flange Alignment Tool is an aid for use in normal maintenance and installation procedures, and enables the realignment of large flanges, for example those that make up the tower sections of a wind turbine.



It is essential that the user familiarises themselves with the contents of this manual prior to using the tool.

This manual contains information for the following tools:

- TFA4™ Tower Flange Alignment Tool

2.

SAFETY INFORMATION

2.1

GENERAL SAFETY

These instructions cover the safe operation and maintenance of THE EQUALIZER **TFA4™** TOWER FLANGE ALIGNMENT tool. The use of this tool should be as part of a broader task-based risk assessment, which should be carried out by the operation supervisor or other competent person.

Failure to comply with the safety information contained within this manual could result in personal injury or equipment damage. Read all instructions, warnings and cautions carefully, and follow all safety precautions.

The safety of the operator, any assisting personnel and the general public is of paramount importance. Always work in accordance with applicable national, local, site & company-wide safety procedures.

2.2

PERSONNEL COMPETENCY

Only personnel deemed competent in the use of mechanical and hydraulic equipment should use this tool.

2.3

DISCLAIMER

Equalizer cannot be held responsible for injury or damage resulting from unsafe product use, lack of maintenance or incorrect product and/or system operation. If in doubt as to the safety precautions and applications, contact Equalizer using the contact details at the back of this manual.

2.4

DEFINITION OF TERMS

A **CAUTION** is used to indicate correct operating or maintenance procedures and practices to prevent damage to, or destruction of equipment or other property.

A **WARNING** indicates a potential danger that requires correct procedures or practices to avoid personal injury.

A **DANGER** is only used when your action or lack of action may cause serious injury or even death.



DO: an illustration showing how the tool should be used.



DON'T: an illustration showing an incorrect way to use a tool.

2.5

HAZARDS



WARNING: ensure all hydraulic components are rated to a safe working pressure of 700 bar (10 000 psi).



WARNING: Do not overload equipment. The risk of hydraulic overloading can be minimised by using the Equalizer Hand Pump, which has a factory-set safety valve preventing the safe working pressure being exceeded.

If alternative hydraulic pumps are used, ensure that there are adequate systems to limit the working pressure to 700 bar (10 000 psi).



CAUTION: ensure components are protected from external sources of damage, such as excessive heat, flame, moving machine parts, sharp edges and corrosive chemicals.



CAUTION: Take care to avoid sharp bends and kinks in hydraulic hoses. Bends and kinks can cause severe back-up pressure and cause hose failure. Protect hoses from dropped objects; a sharp impact may cause internal damage to hose wire strands. Protect hoses from crush risks, such as heavy objects or vehicles; crush damage can cause hose failure.



WARNING: Applying pressure to a damaged hose may cause it to rupture.



WARNING: Immediately replace worn or damaged parts. Use only genuine Equalizer parts from approved distributors or service centres. Equalizer parts have been engineered and manufactured to be fit-for-purpose.



DANGER: To minimise risk of personal injury keep hands and feet away from the tool and workpiece during operation.



WARNING: Always wear suitable clothing and Personal Protective Equipment (PPE). Do not handle pressurised hoses; escaping oil under pressure can penetrate the skin, causing serious injury. Seek medical attention immediately if oil penetration is suspected.



WARNING: Only pressurize complete and fully connected hydraulic systems. Do not pressurize systems that contain unconnected couplers.



CAUTION: Do not lift hydraulic equipment by the hoses or couplers. Use only the designated carrying handles.



CAUTION: Lubricate tools as directed in this manual prior to operation. Use only approved lubricants of high quality, following the lubricant manufacturers instructions.



CAUTION: Only use the designated anchor point for fixing the lanyard. Do not attach the lanyard to the plastic handle.



DANGER: Care should be taken when using the lanyard to avoid entanglement with body parts.



The vibration total value to which this tool is subjected does not exceed 2.5 m/s².

3.

TFA4TM

MECHANICAL FLANGE ALIGNMENT TOOL

The TFA4TM Tower Flange Alignment Tool uses mechanical torque to advance the screw bolt and align the flanges.

3.1 TOOL CAPABILITIES

ALIGNING FORCE

Maximum SWL torque of 68 N·m (50 ft·lb) will generate 4 T (40 kN) aligning force.

3.2 RANGE OF APPLICATION

Minimum and Maximum Flange sizes:

Dimension A: must be between 30 mm and 133 mm (1.18" and 5.23")

Dimension B: bolt-hole diameter must be 24 mm (0.94") or greater

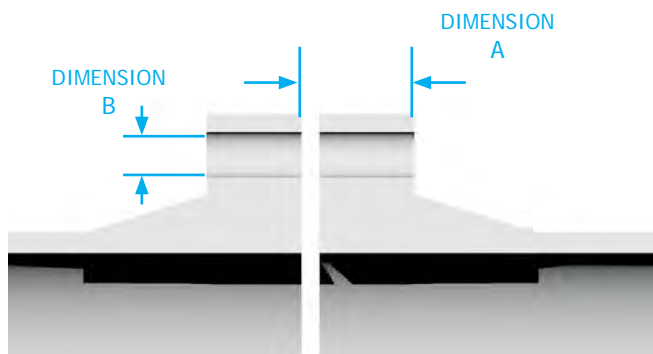

3.3 TFA4TM TOOL FUNCTION

MECHANICAL TOOL OPERATION

The TFA4TM Alignment tool uses mechanical torque to advance the screw bolt and align the flanges. The torque is applied using the supplied Torque Wrench, enabling accurate control of the force applied.



TORQUE WRENCH USAGE

Holding the Torque Wrench in one hand, unlock the knurled handle by turning the locking knob anti-clockwise.

Select the torque setting by turning the knurled handle until the required torque value is indicated.

For example, to set the Torque Wrench to 46 N·m: turn the knurled handle until the 0 on the fine scale aligns with 40 N·m on base scale; now turn slightly further until the 6 on the fine scale aligns with the central line.

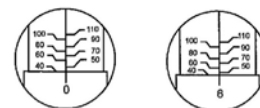

Setting an imperial torque (in ft·lb) is done in exactly the same way.

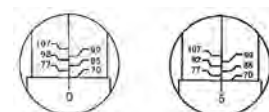

Lock the handle by turning the locking knob clockwise. Do not attempt to turn the grip while it is locked.

Install the supplied socket onto the Torque Wrench and attach to the tool.

Slowly and smoothly pull the handle, gradually applying more force until you feel or hear the Torque Wrench click, indicating that the selected torque has been achieved. Do not continue to apply force after the Torque Wrench has clicked. Special care should be taken when using low torque settings.

TORQUE WRENCH CARE

Prior to storing the Torque Wrench, and between use, leave the Torque Wrench with its lowest torque setting selected.

To clean the Torque Wrench, wipe gently with a damp cloth. Avoid using any detergent or solvent as this may detrimentally affect the factory-fitted internal lubrication of the mechanism.

TFA4TM GENERAL GUIDANCE

The TFA4TM is secured into the lower of the two flanges by fully inserting the lift hook into the bolt hole at the greatest point of misalignment.

The drop leg is adjusted by hand to land on the tower.

The wing retaining screw is loosened to allow the wing to be extended.

The screw bolt is adjusted to land the friction pad on the opposite flange.

Then torque wrench is then attached to the screw bolt and turned to provide the alignment force.

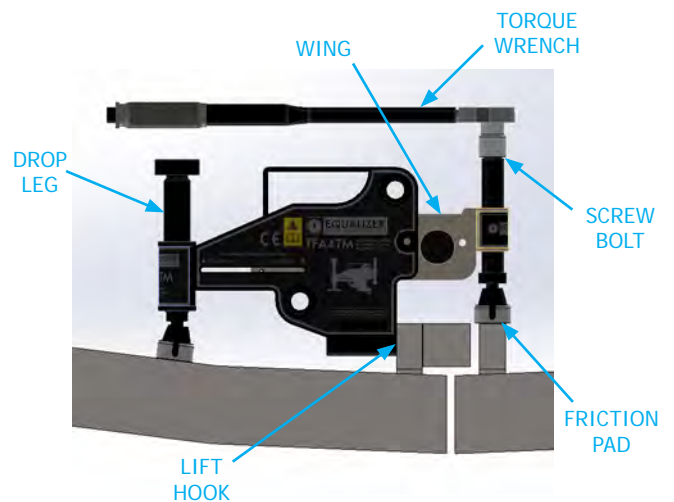

ACTUATING THE TFA4TM

Guide the lift hook into the bolt-hole at the maximum point of misalignment.

Adjust the drop leg down onto the tower by turning the adjustment knob in a clockwise direction. The tool should be held up level within the bolt-hole during adjustment.

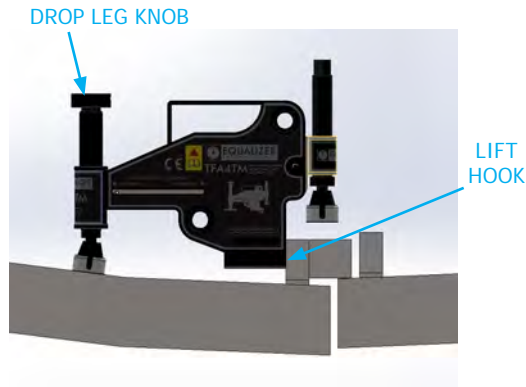

Loosen the wing retaining knob and extend the wing over to the opposite flange.

Rotate the screw bolt onto the surface of the opposite flange. Ensure that the tool is sitting level and that the friction pad on the base of the swivel is in full and even contact with the surface of the opposite flange.

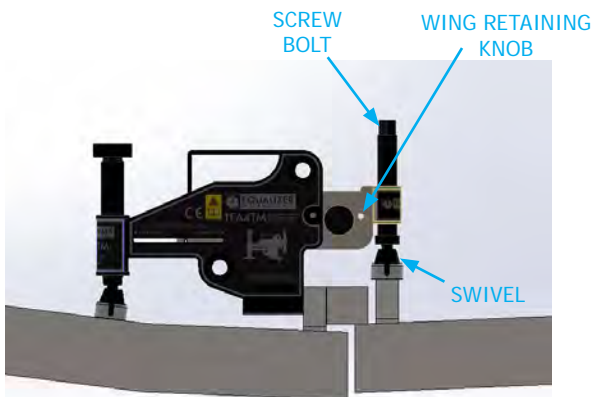

The torque wrench should be set at 19 N·m (14 ft·lb) then attached to the screw bolt.

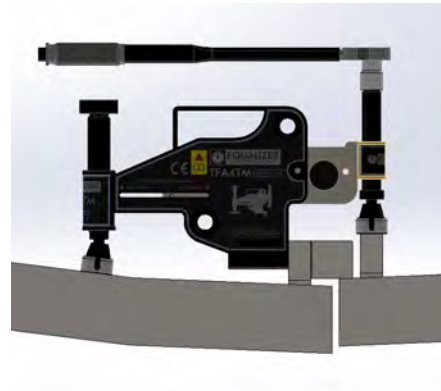

Tighten the screw bolt in a clockwise direction until the flanges come into alignment.

If the torque wrench has clicked and the flanges are still misaligned adjust the torque wrench up to 33 N·m (24 ft·lb) and continue until a maximum torque wrench setting of 68 N·m (50 ft·lb) is reached or the flanges are aligned.

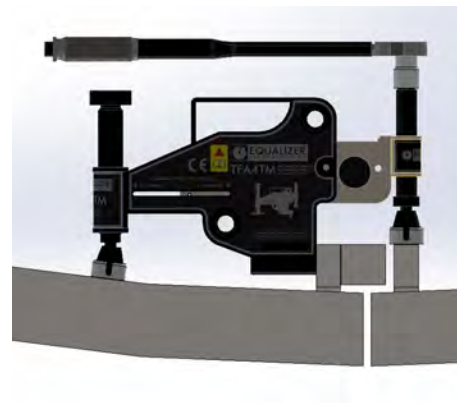

Once in alignment the bolts may be inserted and tightened.

After replacing all of the bolts (apart from the bolt which will go into the bolt-hole in which the TFA4TM is located), remove the tool. Insert the last bolt and tighten.



WARNING: The maximum safe working load is 68 N·m (50 ft·lb). Exceeding 68 N·m (50 ft·lb) will result in damage to the tool.



WARNING: Care should be taken not to drop any of the component parts when removing them from the flange joint. This action will prevent injuries to either the operator's lower limbs or to passers-by.

3.4

TFA4TM KIT CONTENTS

STANDARD KIT

Product Code: TFA4TMSTD

- 1 x TFA4TM Tool
- 1 x Torque Wrench
- 1 x Instruction Manual
- 1 x Carry-Case

Carry-Case Dimensions:

600 mm x 370 mm x 200 mm
(23.6" x 14.6" x 7.9")

Tool only Weight: 8.1 kg (17.9 lb)

Gross Kit Weight: 18 kg (39.7 lb)

3.5

TFA4TM TOOL DIMENSIONS

MINIMUM EXTENSION

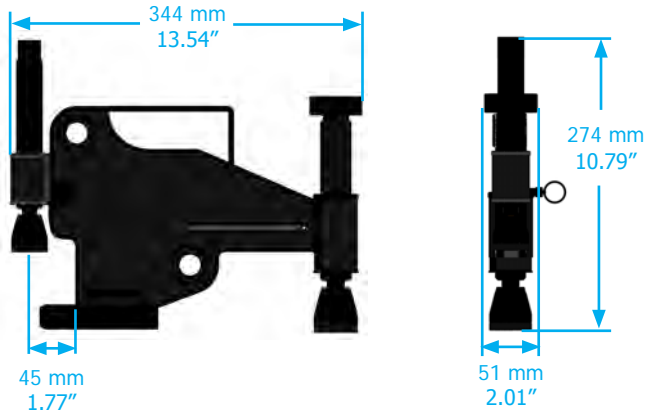

MAXIMUM EXTENSION

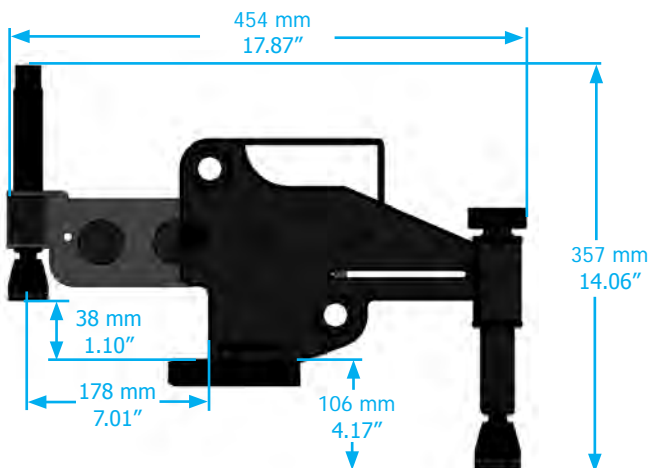

3.6

TFA4TM TOOL MAINTENANCE

INSPECTION

A thorough inspection should be carried out prior to usage, storage or transportation to ensure the completeness and condition of the tool.

Inspection should include:

- visual inspection of the outer parts of the tool, checking for obvious damage, degradation or missing parts.
- visual inspection of the swivel, screw bolt and leg screw, checking for obvious damage and degradation.

Cleaning and servicing should be undertaken as required prior to the tool being used, stored or transported.

CLEANING

To lightly clean the tool, wipe gently with a damp cloth.

If more thorough cleaning is required (for example following immersion in water) carry out the following cleaning procedure:

- strip the tool down, observing the schematics in section 6
- clean the components using detergent, following the manufacturer's guidelines
- rinse the components to remove traces of detergent
- dry the component thoroughly

Inspect, service and lubricate the tool immediately after the cleaning process.

SERVICING

Replace missing, worn or damaged parts. Use only genuine Equalizer parts from approved distributors or service centres. Equalizer parts have been engineered and manufactured to be fit for purpose.

Grease all moving parts by following the Lubrication Procedure prior to usage, storage or transportation.

Ensure rollers, pins and wing remain grit free and that the rollers rotate freely.

Secure the tool upright on a bench.

Using a small flat screw driver, lever out the end of the spiral clips and then rotate anti-clockwise and remove.

Slide the roller shafts out in order to remove the rollers and bearings for examination.

Inspect the roller shafts, rollers and bearings for damage. If there is no damage present then they can be cleaned, greased and re-assembled by reversing the steps above.

Recommended grease: Hi-load bearing grease, e.g. Rocol Sapphire hi-load.

It is important that the thrust bearing is free from dirt and corrosion and rotates freely.

With the use of a penetrating oil such as WD-40 or similar, spray the oil between the thrust plate and the swivel as shown below.

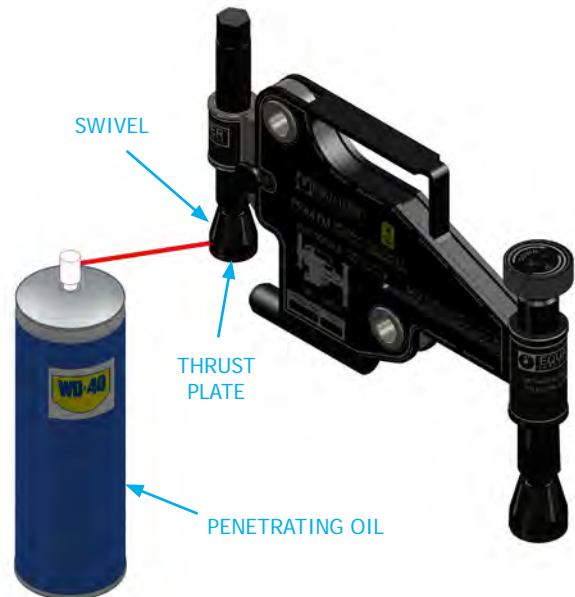

Ensure the thrust plates rotate freely before using the tool to align a flange joint.

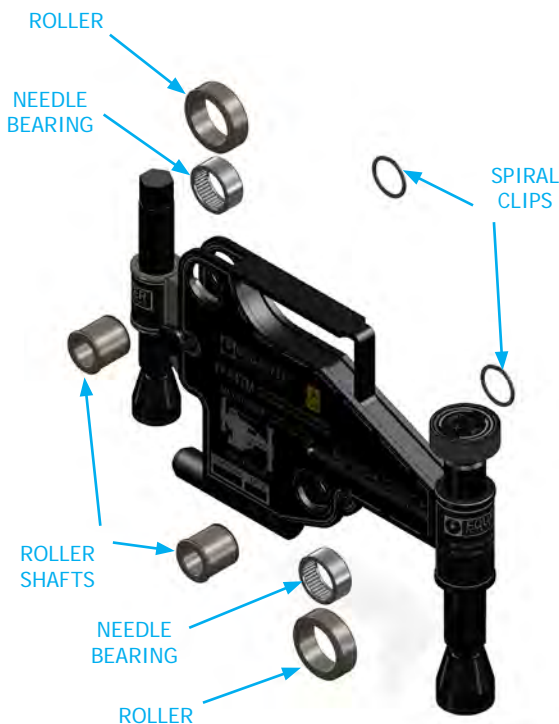

STORAGE AND TRANSPORTATION

Equalizer tools should be stored in a cool, dry place. Tools should always be cleaned, serviced and lubricated prior to storage. Ensure that tools are stored in their designated packing cases.

SUBSEA USAGE

Using TFA4TM Sub-Sea:

The TFA4TM is actuated mechanically and can be used sub-sea providing the following actions are taken:

- The tool is actuated via the torque wrench by a diver.
- The tool is stripped down, cleaned and lubricated immediately to minimise corrosion.

4.

TROUBLESHOOTING

4.1

TFA4TM TROUBLESHOOTING

THE THRUST PLATE IS SLIDING ALONG THE CIRCUMFERENCE OF THE OPPOSITE FLANGE AS THE TOOL IS ALIGNING THE JOINT

POSSIBLE CAUSE:

Grit or dirt on wing, rollers or bearings.

RECOMMENDED ACTION:

Ensure the rollers are rotating freely and that there is no restrictions to the rollers on the wing surfaces such as grit or dirt.

POSSIBLE CAUSE:

Wing is at full extension.

RECOMMENDED ACTION:

Ensure the wing has sufficient travel left in order to allow the joint to align.

THE TOOL IS ATTACHED AND APPEARS TO BE FUNCTIONING PROPERLY, BUT THE JOINT WILL NOT ALIGN

POSSIBLE CAUSE:

There may be something restricting the joint from aligning.

RECOMMENDED ACTION:

Check the area around the joint to establish if there is an obstruction to the joint.

POSSIBLE CAUSE:

The joint may require more than 4 T (40 kN) force to align.

RECOMMENDED ACTION:

If the joint requires more force than that of the 4 T (40 kN) tool, then another method of alignment should be adopted.

THE THRUST PLATE IS TWISTING ON THE CIRCUMFERENCE OF THE FLANGE WHEN THE SCREW BOLT IS TIGHTENED

POSSIBLE CAUSE:

There may be grit or dirt within the swivel / thrust plate.

RECOMMENDED ACTION:

Check that the thrust plate rotates freely. If the thrust plate is not rotating then spray some penetrating liquid into the gap between the swivel and thrust plate in order to loosen it.

5.

REGULATORY INFORMATION

5.1

REGISTERED HEAD OFFICE

EQUALIZER INTERNATIONAL LTD.
Equalizer House
Claymore Drive
Aberdeen
Scotland
AB23 8GD

6.

PARTS LISTS & SERVICE KITS

TFA4TM PARTS LIST

1720000-01 REV 01

ITEM NO.	PART NO	DESCRIPTION	QTY
1	220100-01	MAIN BODY	1
2	1720005-01	MAIN SCREW	1
3	400301-01	SCREW BOLT	1
4	220300-01	SWIVEL	2
5	220400-01	FRICTION PAD	2
6	212000-01	SPRING RING 8MM	2
7	400401-01	SPRING CLIP	2
8	404701-01	THRUST RACE	2
9	404801-01	THRUST WASHER	4
10	1720006-01	FOOT CAP FLANGE	2
11	220500-01	ROLLER SHAFT	2
12	401501-01	NEEDLE BEARING	2
13	401601-01	OUTER ROLLER	2
14	901601-01	SPIROL CLIP	2
15	220700-01	LEG SCREW EXTENSION	1
16	070273-01	DROP LEG KNOB STICKER	1
17	300401-01	M5 SCKT SET SCREW	2
18	401001-01	SLIDING ARM ASS	1
19	403201-01	ROLLER PIN	1
20	1720002-01	BODY PLATE STICKER RIGHT	1
21	1720001-01	BODY PLATE STICKER LEFT	1
22	1720003-01	EQUALIZER LOGO FOR BOSS	1
23	070004-01	LOGO FOR WING	1
24	1720008-01	LOCK NUT	1
25	1720009-01	MAIN SCREW BALL JOINT	1

TFA4TM PARTS LIST

1720000-01 REV 01

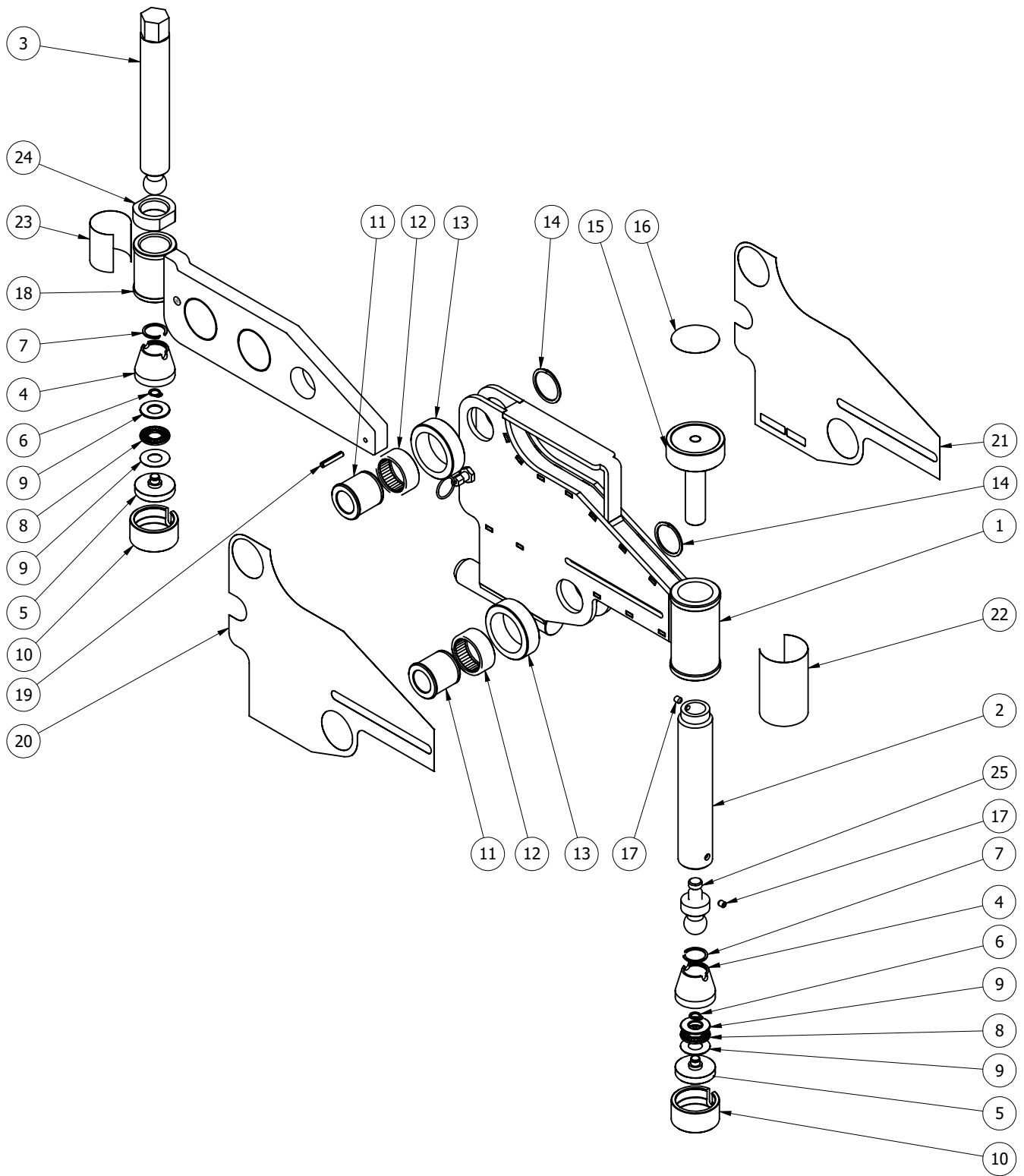



EQUALIZER INTERNATIONAL LTD.

**Head Office
Equalizer House
Claymore Drive
Aberdeen
Scotland
UK
AB23 8GD
t: +44 (0) 1224 701970
f: +44 (0) 1224 823791**

**Houston Office
1330 Yale Street
Houston TX 77008
USA
t: +1 (713) 927-1840**

www.equalizerinternational.com