



# HI-PRESS HYDRAULICS Ltd

## ZU4T, Electric Torque Wrench Pumps



▼ ZU4204TE-Q (Pro Electric serie), ZU4204BE-Q (Classic Electric serie)



# Z Tough, Dependable Innovative CLASSIC



### FIRMWARE for Pro-Series

- Display torque in Nm or Ft.lbs
- Display pressure in bar, MPa or psi
- Torque wrench model is selectable
- “Auto cycle” setting easily programmable.



### Classic Electrical

Basic electrical package includes mechanical contactor, ON/OFF toggle switch, pendant with electro-mechanical push buttons,

24V transformer timer and operator accessible circuit breaker.



### Pro-Series Pump Models

Back-lit LCD and Pressure Transducer featuring Auto-Cycle Technology.

- Digital read-out and “Autocycle” setting
- Display pressure (bar, MPa, psi) or torque (Nm, Ft.lbs) read-out
- Torque wrench model is selectable
- Pump usage information, hour and cycle counts
- Low-voltage warning and recording
- Self-test and diagnostic capabilities
- Information can be displayed in English, French, German, Italian, Spanish and Portuguese
- Pressure transducer is more accurate and durable than analog gauges
- Easy-viewing variable rate display.

- Features Z-Class high-efficiency pump design; higher oil flow and bypass pressure, cooler running and requires 18% less current draw than comparable pumps
- Powerful 1,25 kW universal electric motor provides high power-to-weight ratio and excellent low-voltage operating characteristics
- High-strength, molded composite shroud protects motor and electrical components, while providing an ergonomic, non-conductive handle for easy transport
- Pendant provides additional safety for the operator.

### Pro Series pumps only

- LCD readout provides pressure display and a number of diagnostic and readout capabilities never before offered on a portable electric pump
- Auto-Cycle feature provides continuous cycle operation of the torque wrench as long as the advance button is pressed (pump can be used with or without auto cycle).



◀ Any brand of hydraulic torque wrench can be powered by the portable ZU4T-Series torque wrench pump.



HI-PRESS HYDRAULICS LTD  
RIVERSIDE WORKS,  
FORGE ROAD, WHALEY BRIDGE,  
HIGH PEAK, SK23 7HY

T: 01663 735089 - F: 01663 735090  
sales@hi-press.co.uk

HI-PRESS HYDRAULICS LTD  
UNIT 2, HALL HOUSE IND EST,  
NEW HUTTON, KENDAL,  
CUMBRIA, LA8 0AH

T: 01539 734005 - F: 01539 734006  
cumbria@hi-press.co.uk





# HI-PRESS HYDRAULICS Ltd

## ZU4T-Series, Torque Wrench Pumps



### Z-Class – A Pump For Every Application

Patented Z-Class pump technology provides high by-pass pressures for increased productivity – important in applications using long hose runs and high pressure-drop circuits, like heavy lifting or certain double-acting tools.

Enerpac ZU4T-Series pumps are built to power small to large torque wrenches. Choosing the right ZU4T-Series torque wrench pump for your application is easy.

### Classic Electric Torque Wrench Pumps

- The Classic has traditional electro-mechanical components (transformers, relays and switches) in place of solid-state electronics. The Classic delivers durable, safe and efficient hydraulic power.

### Pro Series Electric Torque Wrench Pump

- Digital (LCD) display features a built-in hour meter, pressure display and shows self-diagnostic, cycle-count and low voltage warning information. These premium features are not available on any other pump – anywhere!
- Auto-Cycle feature provides continuous cycle operation of the torque wrench as long as the advance button is pressed (pump can be used with or without Auto-Cycle feature).

## ZU4T Series



Reservoir Capacity:  
**4,0 - 8,0 litres**

Flow at Rated Pressure:  
**1,0 l/min**

Motor Size:  
**1,25 kW**

Maximum Operating Pressure:  
**700 - 800 bar**



### Torque Wrench Pump Selection

For optimum speed and performance see the torque wrench pump and hose selection matrix.

Page: **38**



### Pump Ratings

**-Q** suffix pumps are for **700 bar** torque wrenches, and include spin-on couplers.

**-E** suffix pumps are for use with Enerpac SQD and HXD-Series **800 bar** torque wrenches, and include polarized lock-ring safety couplers.

Page: **42**



### Gauge and Overlay Kit

Available separately for use with ZU4T-Series Classic: **GT-4015Q** includes gauge and overlays for all S- and W-Series torque wrenches.

**GT-4015** includes gauge and overlays for all SQD and HXD torque wrenches.

<sup>1)</sup> All models meet CE safety requirements and all CSA requirements.  
<sup>2)</sup> European plug and CE EMC directive compliant  
<sup>3)</sup> With NEMA 6-15 plug  
<sup>4)</sup> Select -E suffixed pumps for Enerpac SQD and HXD-Series 800 bar torque wrenches, see page 43.

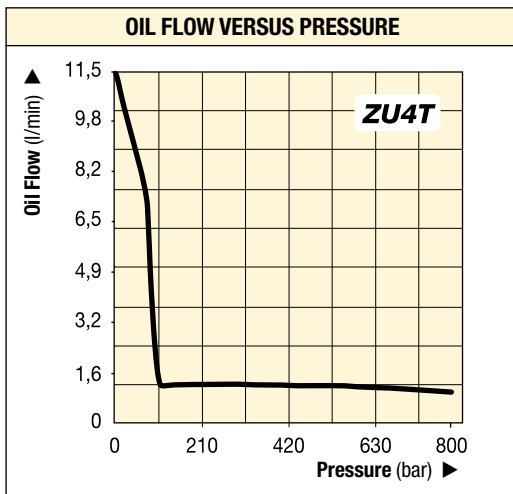

### COMMON PUMP MODEL S

For Use With Torque Wrenches		Model Number <sup>1)4)</sup>	Motor Electrical Specification	Usable Oil Capacity (litres)	(kg)
Pro Series pumps	All wrenches	<b>ZU4204TB-Q</b>	115 VAC, 1-ph	4,0	32
		<b>ZU4208TB-Q</b>	115 VAC, 1-ph	8,0	34
		<b>ZU4204TE-Q <sup>2)</sup></b>	208-240 VAC, 1-ph	4,0	32
		<b>ZU4208TE-Q <sup>2)</sup></b>	208-240 VAC, 1-ph	8,0	34
		<b>ZU4204TI-Q <sup>3)</sup></b>	208-240 VAC, 1-ph	4,0	32
		<b>ZU4208TI-Q <sup>3)</sup></b>	208-240 VAC, 1-ph	8,0	34
Classic pumps	All wrenches	<b>ZU4204BB-QH</b>	115 VAC, 1-ph	4,0	37
		<b>ZU4204BB-Q</b>	115 VAC, 1-ph	4,0	33
		<b>ZU4208BE-QH <sup>2)</sup></b>	208-240 VAC, 1-ph	8,0	38
		<b>ZU4204BE-Q <sup>2)</sup></b>	208-240 VAC, 1-ph	4,0	34
		<b>ZU4208BI-QH <sup>3)</sup></b>	208-240 VAC, 1-ph	8,0	40
		<b>ZU4208BI-Q <sup>3)</sup></b>	208-240 VAC, 1-ph	8,0	36



HI-PRESS HYDRAULICS LTD  
RIVERSIDE WORKS,  
FORGE ROAD, WHALEY BRIDGE,  
HIGH PEAK, SK23 7HY

T: 01663 735089 - F: 01663 735090  
sales@hi-press.co.uk

HI-PRESS HYDRAULICS LTD  
UNIT 2, HALL HOUSE IND EST,  
NEW HUTTON, KENDAL,  
CUMBRIA, LA8 0AH

T: 01539 734005 - F: 01539 734006  
cumbria@hi-press.co.uk







# HI-PRESS HYDRAULICS Ltd

## ZU4T-Serie, Ordering Matrix & Specifications



▼ This is how a ZU4T-Series pump model number is built up:

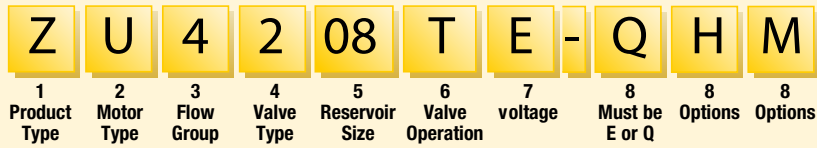

### 1 Product Type

Z = Pump series

### 2 Motor Type

U = Universal electric motor

### 3 Flow Group

4 = 1,0 l/min @ 700 bar

### 4 Valve Type

2 = Torque wrench valve

### 5 Reservoir Size

04 = 4,0 litres usable oil  
08 = 8,0 litres usable oil

### 6 Valve Operation

T = Pro Electric Serie pump with solenoid valve and pendant, LCD Electric and pressur transducer  
B = Classic Electric pump with solenoid valve and pendant.

### 7 Voltage

B = 115V, 1 ph, 50/60 Hz  
E = 208-240V, 1 ph, 50/60 Hz (with European plug CE RF compliant)  
I = 208-240V, 1 ph, 50/60 Hz (with NEMA 6-15 plug)

### 8 Options

E = with 800 bar coupler for use with HXD and SQD-Series or other wrenches  
Q = with 700 bar coupler for use with S and W-Series or other wrenches  
H = Heat exchanger  
K = Skid bar  
M = 4-wrench manifold  
R = Roll cage



### How to order your ZU4T-Series torque wrench pump

Ordering Example

Model No. **ZU4208TE-QMHK**

**700 bar Pro Electric Series** pump for use with Enerpac S and W-Series and other 700 bar torque wrenches, 230V motor, 8 litres reservoir, 4-wrench manifold, heat exchanger and skidbar.

Refer to the torque wrench pump selection matrix for optimum wrench, pump and hose combinations.

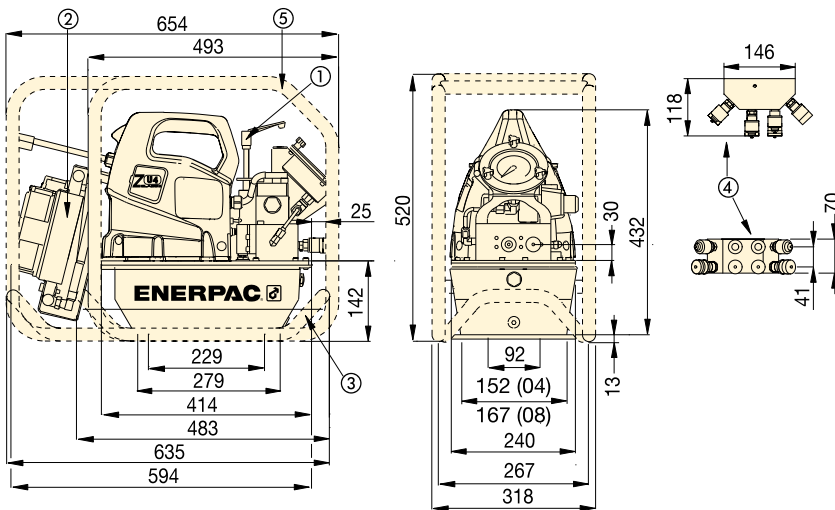

### ZU4T-Series Torque Wrench Pumps

- ① User adjustable relief valve
- ② Heat Exchanger (optional)
- ③ Skidbar (optional)
- ④ 4-wrench manifold (optional)
- ⑤ Roll cage (optional)

ZU4T-Series Performance Chart

Motor Size (kW)	Output Flow Rate (l/min)				Motor Electrical Specification (Volt - Phase - Hz)	Sound Level (dBA)	Relief Valve Adjustment Range (bar)
	7 bar	50 bar	350 bar	700 bar			
1,25	11,5	8,8	1,2	1,0	115 - 1 - 50/60 208-240 - 1 - 50/60	85-90	124-700 *

\* Pump type (-Q) shown, (-E) range is 124-800 bar.



### Torque Wrench Hoses

Use Enerpac twin safety hoses to connect your torque wrench to the pump.

For 700 bar	Model Nr.
6 m long, 2 hoses	THQ-706T
12 m long, 2 hoses	THQ-712T
For 800 bar	Model Nr.
6 m long, 2 hoses	THC-7062
12 m long, 2 hoses	THC-7122



HI-PRESS HYDRAULICS LTD  
RIVERSIDE WORKS,  
FORGE ROAD, WHALEY BRIDGE,  
HIGH PEAK, SK23 7HY

T: 01663 735089 - F: 01663 735090  
sales@hi-press.co.uk

HI-PRESS HYDRAULICS LTD  
UNIT 2, HALL HOUSE IND EST,  
NEW HUTTON, KENDAL,  
CUMBRIA, LA8 0AH

T: 01539 734005 - F: 01539 734006  
cumbria@hi-press.co.uk





# HI-PRESS HYDRAULICS Ltd

## ZU4T-Series, Pump Options



### Heat Exchanger

- Removes heat from the bypass oil to provide cooler operation
- Stabilizes oil viscosity, increasing oil life and reduces wear of pump and other hydraulic components.



### Skid Bar

- Provides greater pump stability on soft or uneven surfaces
- Provides easy two-handed lift.

## ZU4T Series



Reservoir Capacity:

**4,0 - 8,0 litres**

Flow at Rated Pressure:

**1,0 l/min**

Motor Size:

**1,25 kW**

Maximum Operating Pressure:

**700 - 800 bar**

Accessory Kit * Model Nr.	Can be used on ZU4-Series torque wrench pumps
<b>ZHE-U115</b>	115 Volt pumps
<b>ZHE-U230</b>	230 Volt pumps

\* Add suffix **H** to pump model number for factory installation.

Heat Exchanger adds 4,1 kg to pump weight.

Ordering Example: **ZU4208TE-QH**

Accessory Kit * Model Nr.	Can be used on ZU4-Series torque wrench pumps
<b>SBZ-4</b>	04 and 08 reservoir <sup>1)</sup>
<b>SBZ-4L</b>	04 and 08 reservoir <sup>2)</sup>

\* Add suffix **K** to pump model number for factory installation.

<sup>1)</sup> For pump without heat exchanger 2,2 kg.

<sup>2)</sup> For pump with heat exchanger 3,2 kg.

Ordering Example: **ZU4208TE-QK**



### Roll Cage

- Protects pump
- Provides greater pump stability.



### 4-Wrench Manifold

- For simultaneous operation of multiple torque wrenches
- Can be factory installed or ordered separately.

Accessory Kit * Model Nr.	Can be used on ZU4-Series torque wrench pumps
<b>ZRC-04</b>	04 and 08 reservoir <sup>1)</sup>
<b>ZRC-04H</b>	04 and 08 reservoir <sup>2)</sup>

\* Add suffix **R** for factory installation.

<sup>1)</sup> For pump without heat exchanger 5 kg.

<sup>2)</sup> For pump with heat exchanger 7 kg.

Ordering Example: **ZU4208TE-QR**

Accessory Kit * Model Nr.	Can be used on ZU4-Series torque wrench pumps
<b>ZTM-E</b>	for 800 bar torque wrenches
<b>ZTM-Q</b>	for 700 bar torque wrenches

\* Add suffix **M** for factory installation.

Weight 4,0 kg.

Ordering Example: **ZU4208TE-QM**

▼ Most hydraulic torque wrenches can be powered by the Enerpac ZU4T-Series torque wrench pump.



HI-PRESS HYDRAULICS LTD  
RIVERSIDE WORKS,  
FORGE ROAD, WHALEY BRIDGE,  
HIGH PEAK, SK23 7HY

T: 01663 735089 - F: 01663 735090  
sales@hi-press.co.uk

HI-PRESS HYDRAULICS LTD  
UNIT 2, HALL HOUSE IND EST,  
NEW HUTTON, KENDAL,  
CUMBRIA, LA8 0AH

T: 01539 734005 - F: 01539 734006  
cumbria@hi-press.co.uk

