

# Mini Hydraulic Cutter-Spreader

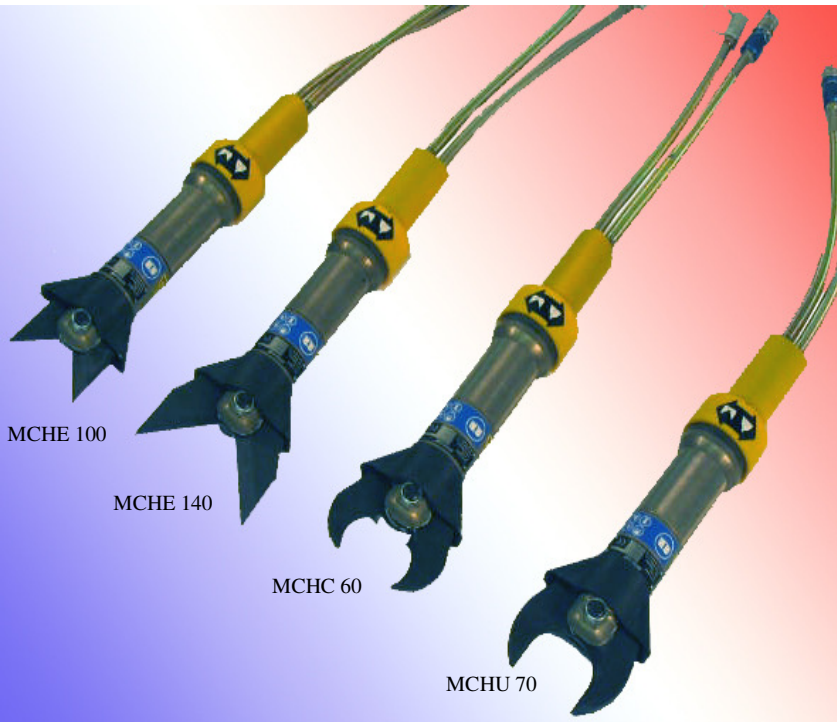

▼ Mini Hydraulic Cutter-Spreader MCHE 100 - MCHE140 - MCHC 60 - MCHU 70



Its light weight  
and low space  
requirement  
provides a very  
effective tool

## DESCRIPTION

High strength hardened light alloy unit. Can be used in wet conditions.

Tool comprises :

- 1 Double acting cylinder
- 1 Cutter body
- 1 Ergonomically shaped control handle with integral safety device
- 1 Set of 0.5 meter long hoses with automatic locking, anti-pollution quick action couplers with metal protection stoppers
- 2 Cutting blades in high strength corrosion resistant hardened forged steel (4 blade models)
- Hose relief valve on end stopper

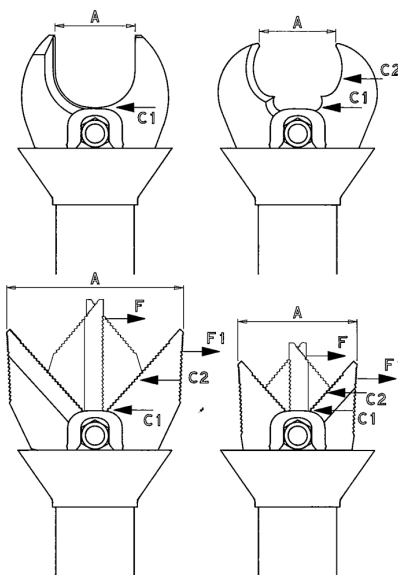

## CHARACTERISTICS

Model	MCHE100	MCHE140	MCHC60	MCHU70
Blade shapes.	straight short	straight	curved	in U
Operating pressure	700 bar	700 bar	700 bar	700 bar
Cutting force C1	190 kN	190 kN	157 kN	190 kN
Cutting force C2	102 kN	72 kN	88 kN	-
Spreading force F	20 kN	14 kN	-	-
Spreading force F1	23 kN	16 kN	-	-
Maximum opening A	100 mm	140 mm	64 mm	70 mm
Dimensions (mm)	492x136x90	530x136x90	499x136x90	502x136x90
Weight	4,7 kg	5,0 kg	5,0 kg	5,0 kg
Tool classification EN 13204	AC 59-C/ 4,7	AC 94-C/ 5	AC 66 -C/ 5	AC 70 -B/ 5
Compliance Standards	NF-EN-NFPA	NF-EN-NFPA	NF-EN-NFPA	NF-EN-NFPA

Powerful, Lightweight and Reliable in Rescue Operations

NO CONTRACTUAL DOCUMENT



Chemin du Lyonnais - 69720 St Bonnet de Mure FRANCE- 33 (0) 4 72 48 90 05 - fax:33 (0) 4 72 48 90 03

☎:Site : [www.hydram.com](http://www.hydram.com) - E-mail : [hydram@wanadoo.fr](mailto:hydram@wanadoo.fr)