

# Hydraulic Cutter-Spreaders

▼ Hydraulic Cutter-Spreaders CHE 290 / 2900



Its powerful and lightweight construction makes it possible to cut high gauge, sheet metals, pipes, structures and profiles.

## DESCRIPTION

High resistant light alloy unit with anti-wear treatment.  
Can be used in wet conditions.

Tool comprises of :

- 1 Double acting cylinder.
- 1 Ergonomically shaped control handle with a built in safety feature.
- 1 Set of hoses 0.5m long with automatically locking anti-pollution, HP quick couplers fitted with metallic protection stoppers.
- 2 straight cutting blades in high strength forged steel blades with anti-corrosion treatment.
- 1 U type holding handle.
- Pressure relief valve for hose on coupler end.

## CHARACTERISTICS

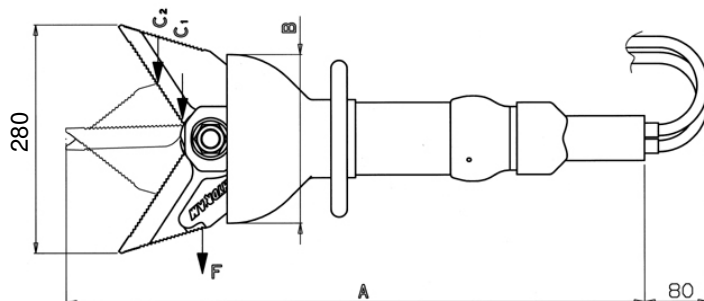

Model	CHE 290	CHE 2900
Operating pressure	700 bar	700 bar
Cutting force C1	347 kN	461 kN
Cutting force C2	133 kN	176 kN
Spreading force F	122 kN	163 kN
Maximum opening A	280 mm	280 mm
Dimensions (mm)	722x210x165	733x252x195
Weight	14,4 kg	16 kg
Tool classification EN13204	CC 103 - H14,4	CC 102 H 16
Compliance standards	NF-EN-NFPA	NF-EN-NFPA

Powerful, Lightweight and Reliable in Rescue Operations