

P-Series, Low Pressure Hand Pumps

▼ Shown from left to right: P-51, P-25, P-18



- Bi-directional pumping on the P-25 and P-50 allows operation on both handle strokes
- External load-release valve
- Internal pressure-relief valve for overload protection
- P-51 can be operated in horizontal and vertical position with pump head and oil outlet facing downwards
- P-50 and P-51 pump oil in both forward and reverse handle movement improving overall efficiency, ideal when mounting space is restricted.



Gauges

Minimize the risk of overloading and ensure long, dependable service from your equipment. Refer to the System Components section for a full range of gauges.

Page: 121



Foot Pump Conversion Kits

Convert your P-18 to foot power with the PC-10 Kit. Includes instructions for easy conversion.



Foot Pump P-392FP

For handsfree operation the lightweight and robust P-392FP Foot Pump is the perfect choice.

Page: 75

▼ P-18 hand pump used for locking the rotating table for marble polishing.



Pump Type	Usable Oil Capacity (cm ³)	Model Number	Pressure Rating (bar)	Oil Displacement per Stroke (cm ³)	Max. Handle Effort (kg)
Single-Speed	295	P-18	200	2,62	26
	3277	P-25	175	9,50	27
	3277	P-50	350	4,75	27
	819	P-51	200	4,10	27

Low Pressure Hand Pumps

P Series



Reservoir Capacity:
295-3277 cm³

Flow at Rated Pressure:
2,62-9,50 cm³/stroke

Operating Pressure:
175-350 bar

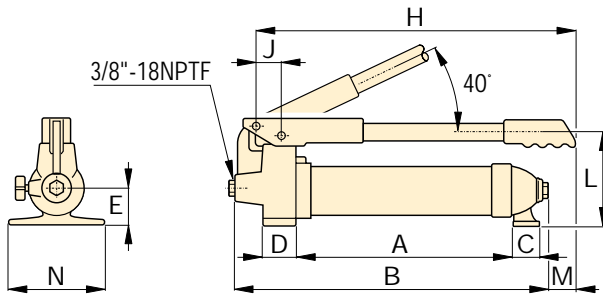

P-18

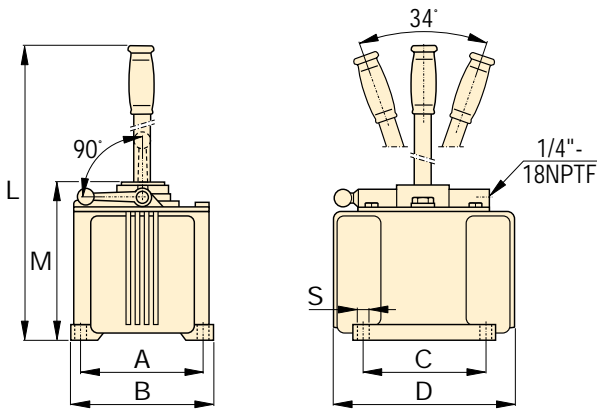

P-25, P-50

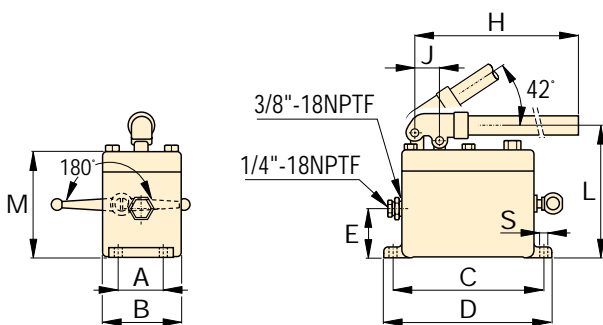

P-51

P-25 hand pumps used with RC-serie cylinders to keep wooden layers under pressure during lamination of plates.



Hoses

Enerpac offers a complete line of high quality hydraulic hoses. To ensure the integrity of your system, specify only genuine Enerpac hydraulic hoses.

Page: 122



Multifluid Hand Pumps

Corrosion resistant hand pumps for low pressure filling and high pressure testing applications, suitable for a wide range of fluids.

Page: 74



Piston Stroke	Dimensions (mm)												Model Number
	(mm)	A	B	C	D	E	H	J	L	M	N	S	
20,6	210	327	33	38	48	216	30	111	13	133	-	5,0	P-18
38,1	152	173	152	240	-	-	-	684	200	-	10	16,3	P-25
38,1	152	173	152	240	-	-	-	684	200	-	10	16,8	P-50
25,4	52	92	181	200	57	610	29	160	129	-	9	5,4	P-51